

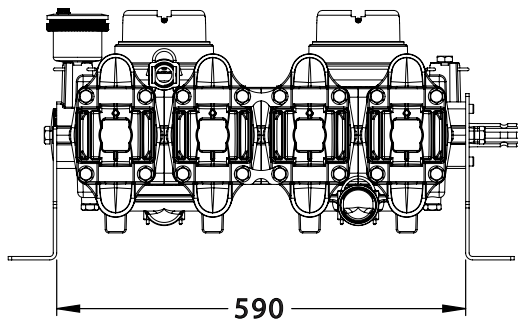

# P200/P200

Specifications in mm  
Angaben in mm

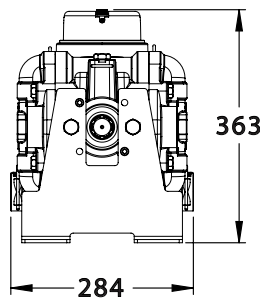
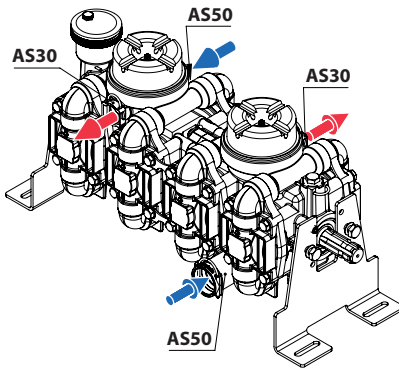

Capacity at 5 bar	Literleistung bei 5 bar	2 x 200 l/min
Article no.	Artikel-Nr.	83126*
Working diaphragms	Arbeitsmembrane	8 x NBR
Accumulator diaphragms	Druckspeichermembrane	1 x NBR
Inlet- $\phi$ suction	Einlass- $\phi$ Saugseite	2 x AS50
Outlet- $\phi$ pressure	Auslass- $\phi$ Druckseite	2 x AS30
Weight	Gewicht	50 kg

\* Setup pto protection, including oil filling  
\* Aufbau mit Schutztopf, inkl. Ölfüllung

Basic Parameters Eckdaten		
Nominal speed [rpm]	Nenn Drehzahl [U/min]	540
Speed range [rpm]	Drehzahlbereich [U/min]	450 — 600
Permanent pressure [bar]	Druck, auf Dauer [bar]	max. 15
Short-term pressure [bar]	Druck, kurzzeitig [bar]	max. 20
Spline shaft	Zapfwelle	DIN 9611 ISO 500

Lubrication: Oil bath	Schmierung: Ölbad
Materials: Cast aluminium, partially anodised, stainless steel, NBR seals, POM	Material: Aluminiumguss, teilweise eloxiert, Edelstahl, NBR-Dichtungen, POM

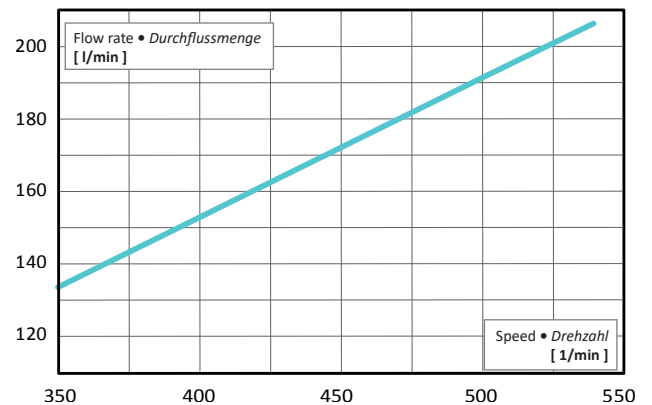

Power Consumption at 540 rpm Leistungsaufnahme bei 540 U/min	5 bar	10 bar	15 bar
	5,5 kW	9,0 kW	13 kW



Options:  
Desmopan® Diaphragms  
Hydraulic drive  
Sonderausführungen:  
Desmopan® Membranen  
Hydromotor